

**PULSE DRIVEN VERTICAL BOOSTER**

ADVANCE DATA

- OUTPUT CURRENT UP TO 2.5App
- 70V MAXIMUM FLYBACK VOLTAGE
- INTERNAL FLYBACK GENERATOR
- INTERNAL REFERENCE VOLTAGE GENERATOR
- INTERNAL RAMP GENERATOR
- SAWTOOTH STARTED BY THE END OF SYNC PULSE OR BY AN INTERNAL MONOSTABLE
- THERMAL PROTECTION

**DESCRIPTION**

The STV9303 is a pulse driven vertical booster intended for use in color TV. It includes a vertical ramp generator specially designed to fit with deflection processors like STV2102 or STV2110 which provide a 10.5 line length vertical pulse. The discharging of the sawtooth capacitor is triggered by the trailing edge of the vertical sync and the charging by the leading edge.

During the sync pulse duration, the sawtooth will remain at its bottom value. Another possibility is to use the internal monostable (by connecting an external capacitor on Pin 5) to define the point where the sawtooth will restart. This second possibility is very useful to avoid interlacing problems when using a conventional deflection processor delivering a small duration vertical pulse.

The STV9303 includes a very efficient power amplifier for direct driving of a TV picture tube in B & W or color television.

For power consumption saving, a flyback generator is also included. The current and voltage capabilities (2.5App max output current and 70V flyback peak voltage), make this IC also suitable for large screen TV sets.

Thermal protection is also provided.

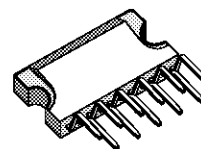

**CLIPWATT 11**  
(Plastic Package)

**ORDER CODE : STV9303W**

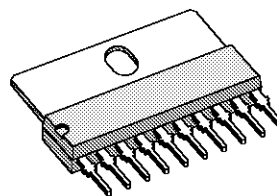

**SIP10**  
(Plastic Package)

**ORDER CODE : STV9303**

PIN CONNECTIONS

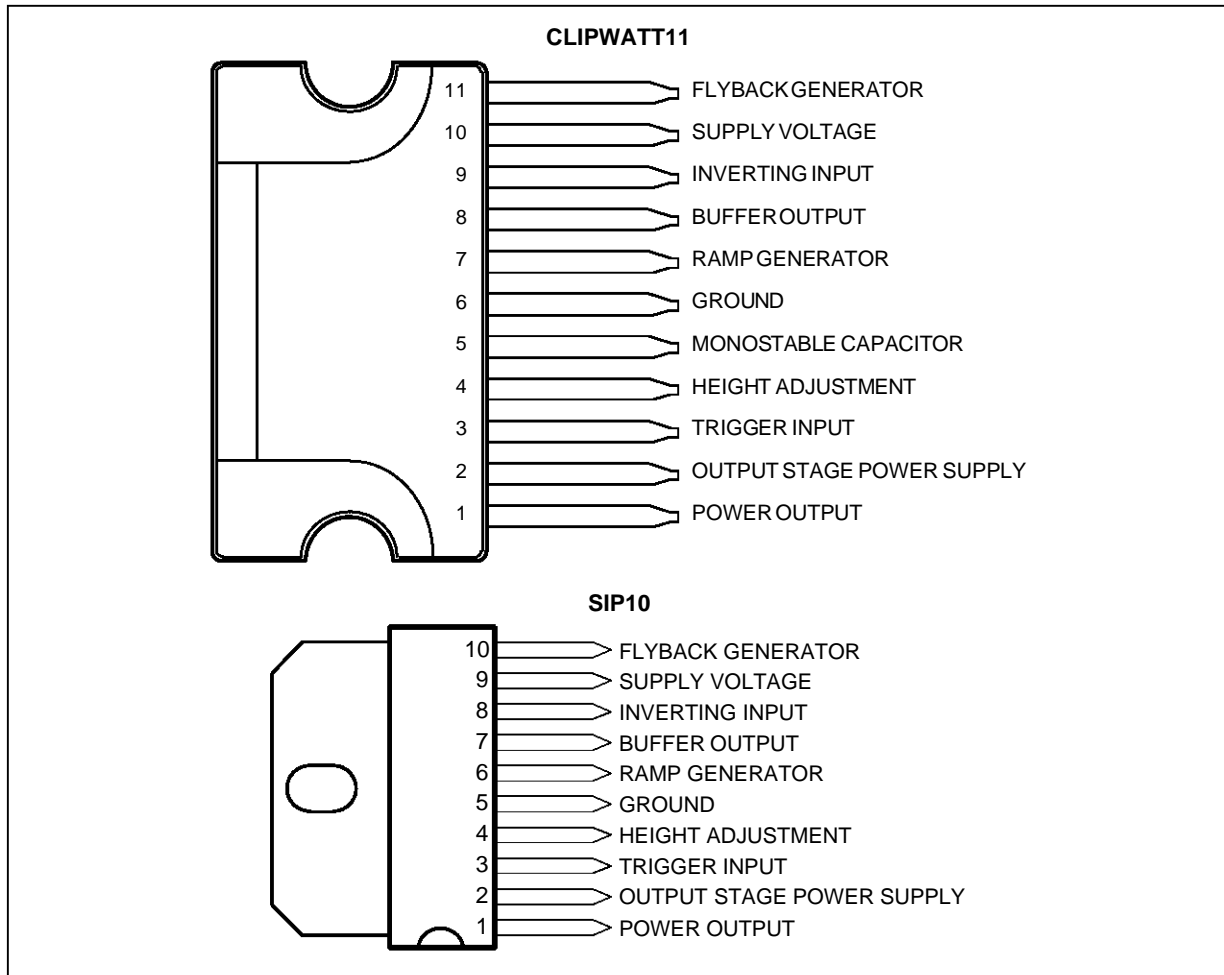

9303V-02.EPS/9303V-01.EPS

BLOCK DIAGRAM (CLIPWATT)

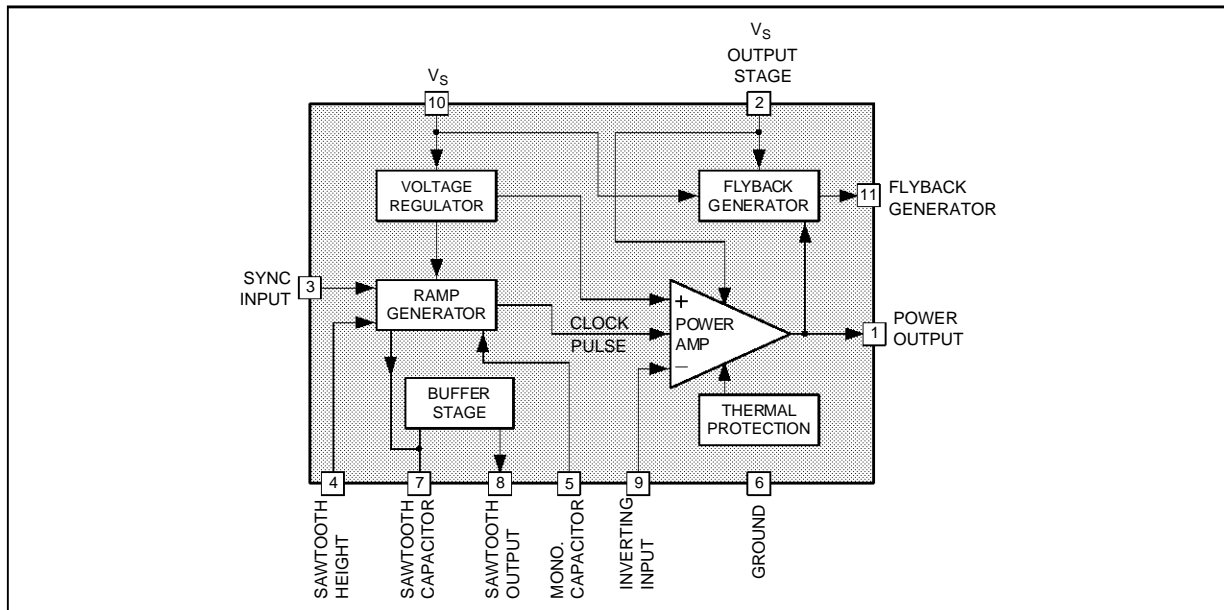

9303V-03.EPS

**ABSOLUTE MAXIMUM RATINGS (CLIPWATT Pin Connections)**

Symbol	Parameter	Pins	Value	Unit
V <sub>S</sub>	Supply Voltage	10	35	V
V <sub>F</sub> , V <sub>O</sub>	Flyback Voltage	1-2	70	V
V <sub>I-</sub>	Amplifier Input Voltage	9	V <sub>S</sub>	V
I <sub>OP</sub>	Peak Output Current	1	1.5	A
I <sub>11</sub>	Flyback DC Current at V <sub>O</sub> < V <sub>S</sub>	11	100	mA
I <sub>11</sub>	Flyback Peak Current (f = 50 or 60Hz, T <sub>fly</sub> < 1.5ms)	11	1.8	A
V <sub>3</sub>	Trigger Input Voltage	3	V <sub>S</sub>	V
T <sub>stg</sub>	Storage Temperature		-40, +150	°C
T <sub>j</sub>	Junction Temperature		Internally limited	

9303V-01.TBL

**THERMAL DATA**

Symbol	Parameter		Value	Unit
T <sub>pt</sub>	Junction Temperature at Thermal Shutdown	Typ.	140	°C
T <sub>ph</sub>	Thermal Protection Hysteresis	Typ.	25	°C
R <sub>th (j-c)</sub>	Junction-case Thermal Resistance	CLIPWAT11 SIP10 Max. Max.	3 10	°C/W °C/W

9303V-02.TBL

**ELECTRICAL CHARACTERISTICS (CLIPWATT Pin Connections)**(V<sub>S</sub> = 35V, T<sub>amb</sub> = 25°C, unless otherwise specified)

Symbol	Parameter	Test Conditions	Min.	Typ.	Max.	Unit
I <sub>2</sub>	Pin 2 Quiescent Current	I <sub>1</sub> = 0, I <sub>11</sub> = 0		16	36	mA
I <sub>10</sub>	Pin 10 Quiescent Current	I <sub>1</sub> = 0, I <sub>11</sub> = 0		15	30	mA
-I <sub>7</sub>	Ramp Generator Bias Current	V <sub>7</sub> = 0			1	μA
-I <sub>7</sub>	Ramp Generator Current	V <sub>7</sub> = 0, -I <sub>4</sub> = 20μA	18.5	20	21.5	μA
dl <sub>7</sub> /I <sub>7</sub>	Ramp Generator Linearity	V <sub>7</sub> = 0 to 12V, -I <sub>4</sub> = 20μA		0.2	1	%
V <sub>1L</sub>	Out Saturation Voltage to GND	I <sub>1</sub> = 0.1A I <sub>1</sub> = 1.25A		0.1 1.2	1 2.0	V V
V <sub>1H</sub>	Out Saturation Voltage to V <sub>S</sub>	-I <sub>1</sub> = 0.1A -I <sub>1</sub> = 1.25A		0.9 1.6	1.6 3.0	V V
V <sub>4</sub>	Reference Voltage	-I <sub>4</sub> = 20μA	6.3	6.6	6.9	V
dV <sub>4</sub> /V <sub>S</sub>	Reference Voltage Drift versus V <sub>S</sub>	V <sub>S</sub> = 10V to 35V		1	2	mV/V
dV <sub>4</sub> /dI <sub>4</sub>	Reference Voltage Drift versus I <sub>4</sub>	I <sub>4</sub> = 10μA to 30μA		0.1	1	mV/μA
V <sub>R</sub>	Internal Reference Voltage		4.15	4.40	4.65	V
V <sub>D11-10</sub>	Diode Fwd Voltage	I <sub>D</sub> = 1.25A		1.5	3	V
V <sub>D1-2</sub>	Diode Fwd Voltage	I <sub>D</sub> = 1.25A		1.5	3	V
G <sub>V</sub>	Output Stage Open Loop Gain	f = 100Hz		70		dB
V <sub>is</sub>	V10-11 Saturation Voltage	-I <sub>11</sub> = 1.25A		1.5	3.0	V
V <sub>11</sub>	Pin 11 Saturation Voltage	I <sub>11</sub> = 20mA		0.8	2	V
V <sub>3</sub>	Trigger Input Threshold		2.6	3.0	3.4	V
V <sub>8</sub>	Sawtooth Pedestall Voltage			1.85		V
I <sub>1</sub>	Peak-to-peak Operating Current Range		0.4		2.5	A
V <sub>7M</sub>	Max. Voltage on Pin 7		12			V
I <sub>7</sub>	Min. Discharging Current		5			mA
K1	Delay between end of Sync Pulse and beginning of Sawtooth versus value of Capacitor on Pin 5			100		μs/nF
t <sub>do</sub>	Max. Delay between end of Sync Pulse and beginning of Sawtooth Capacitor charging without Capacitor on Pin 5			2	10	μs

9303V-03.TBL

WAVEFORMS

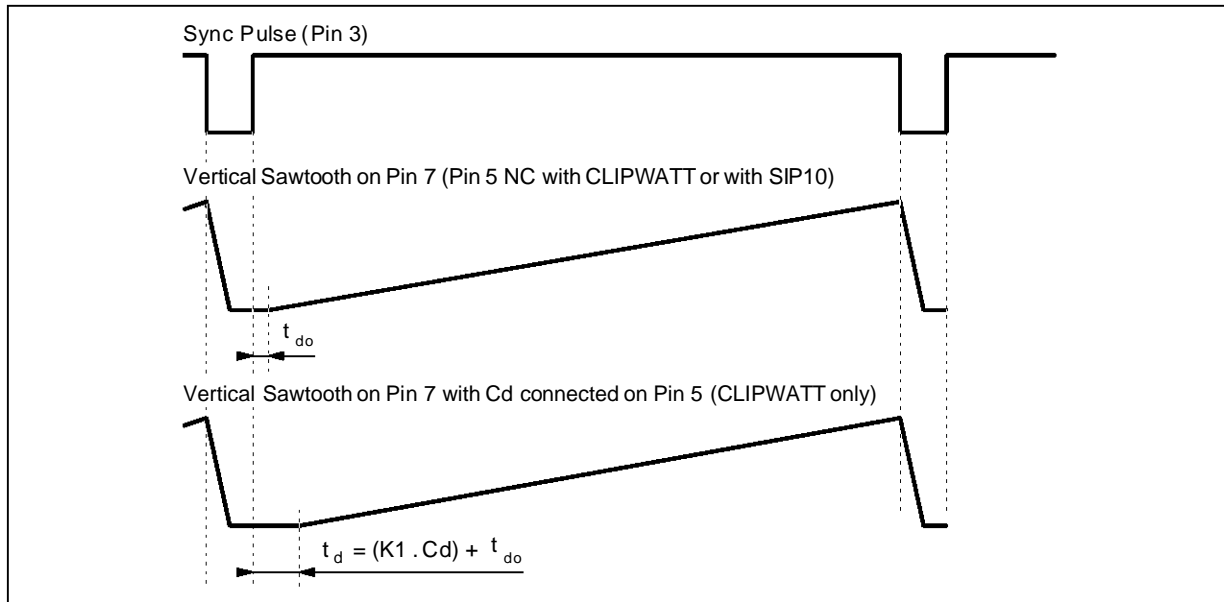

9303V-04.EPS

APPLICATION CIRCUIT (CLIPWATT)

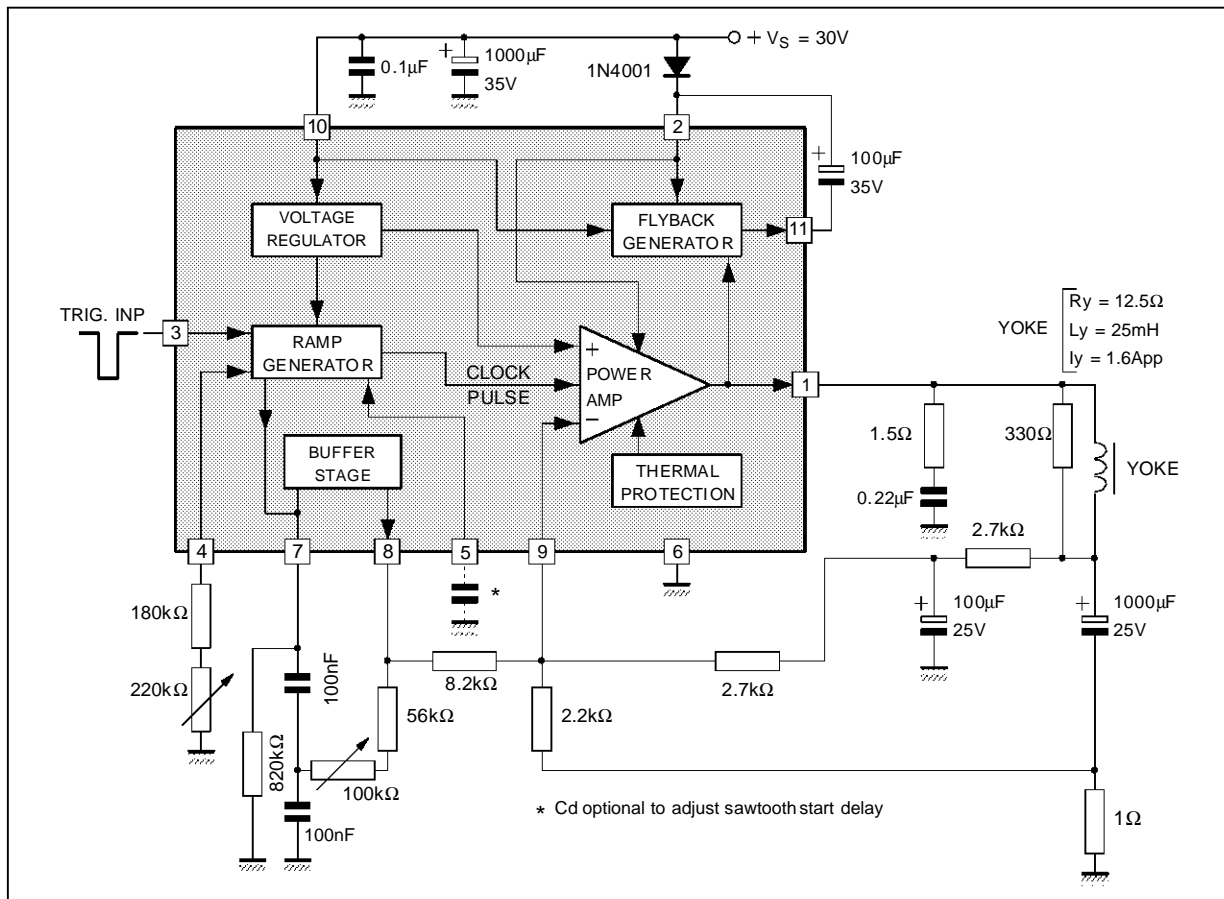

9303V-05.EPS

**PACKAGE MECHANICAL DATA**  
11 PINS - PLASTIC CLIPWATT

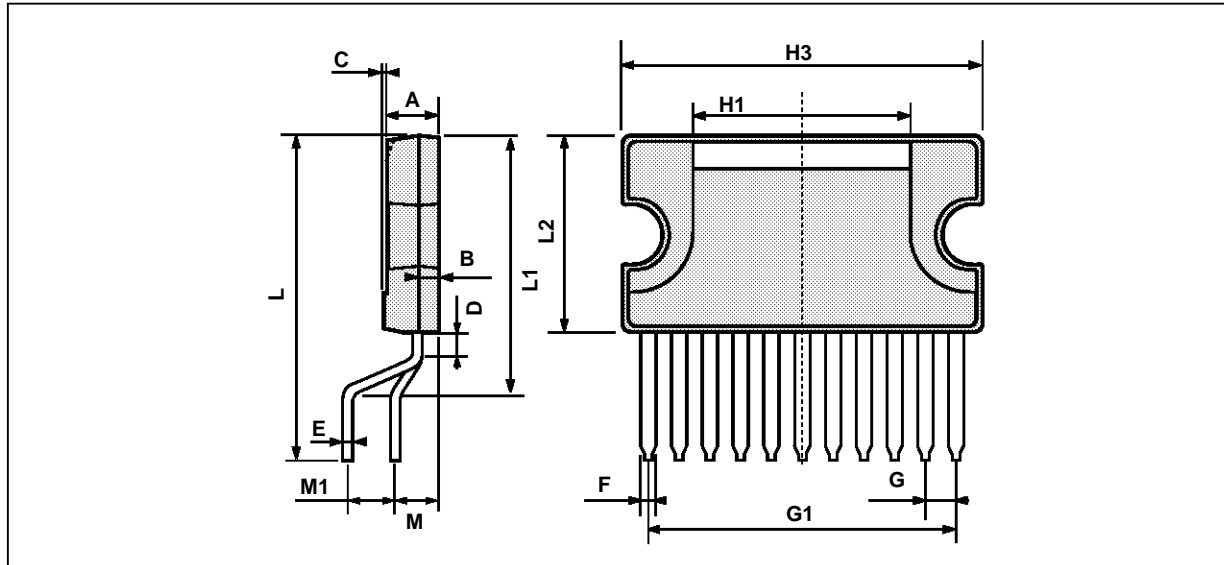

PM-CPW11.EPS

Dimensions	Millimeters			Inches		
	Min.	Typ.	Max.	Min.	Typ.	Max.
A			3.10			0.122
B			1.10			0.04
C		0.15			0.006	
D		1.50			0.059	
E		0.52			0.02	
F		0.80			0.03	
G		1.70			0.066	
G1		17			0.66	
H1		12.00			0.48	
H3		20.00			0.79	
L		17.90			0.70	
L1		14.40			0.57	
L2		11.00			0.43	
M		2.54			0.1	
M1		2.54			0.1	

CPW11.TBL

# STV9303

## PACKAGE MECHANICAL DATA

10 PINS - PLASTIC SIP

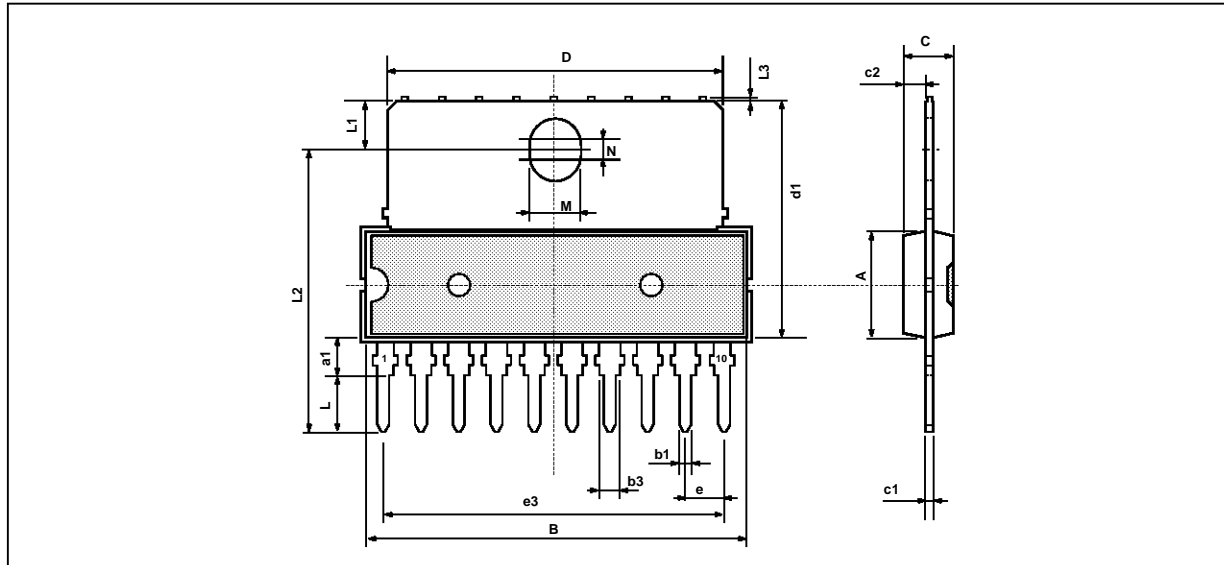

PM-SIP10.EPS

Dimensions	Millimeters			Inches		
	Min.	Typ.	Max.	Min.	Typ.	Max.
A			7.1			0.280
a1	2.7		3	0.106		0.118
B			24.8			0.976
b1		0.5			0.020	
b3	0.85		1.6	0.033		0.063
C		3.3			0.130	
c1		0.43			0.017	
c2		1.32			0.052	
D			23.7			0.933
d1		14.5			0.571	
e		2.54			0.100	
e3		22.86			0.900	
L	3.1			0.122		
L1		3			0.118	
L2		17.6			0.693	
L3			0.25			0.010
M		3.2			0.126	
N		1			0.039	

SIP10.TBL

Information furnished is believed to be accurate and reliable. However, SGS-THOMSON Microelectronics assumes no responsibility for the consequences of use of such information nor for any infringement of patents or other rights of third parties which may result from its use. No licence is granted by implication or otherwise under any patent or patent rights of SGS-THOMSON Microelectronics. Specifications mentioned in this publication are subject to change without notice. This publication supersedes and replaces all information previously supplied. SGS-THOMSON Microelectronics products are not authorized for use as critical components in life support devices or systems without express written approval of SGS-THOMSON Microelectronics.

© 1994 SGS-THOMSON Microelectronics - All Rights Reserved

Purchase of I<sup>2</sup>C Components of SGS-THOMSON Microelectronics, conveys a license under the Philips I<sup>2</sup>C Patent. Rights to use these components in a I<sup>2</sup>C system, is granted provided that the system conforms to the I<sup>2</sup>C Standard Specifications as defined by Philips.

SGS-THOMSON Microelectronics GROUP OF COMPANIES

Australia - Brazil - China - France - Germany - Hong Kong - Italy - Japan - Korea - Malaysia - Malta - Morocco  
The Netherlands - Singapore - Spain - Sweden - Switzerland - Taiwan - Thailand - United Kingdom - U.S.A.